

Name: _____
Mathematics Period 3

Date: 5/1/15
Ms. Wilson

**Expression and Equations
Classwork**

For questions 1-4, evaluate each expression for the given values of the variables. Round decimal answers to the nearest hundredth as necessary, and write fractional answers in simplest form.

1.) $3x + 2y$ when $x = 4$ and $y = 11\frac{1}{4}$

2.) $3(a + b) + 2$ when $a = 6$ and $b = 5$

3.) $\frac{A-B}{2} + 9$ when $A = 26.32$ and $B = 8.12$

4.) $5D$ when $D = 4\frac{9}{16}$

For questions 5-7, solve each equation for the given variable.

5.) $x + 6 = 52$

6.) $26 = 11.6 + y$

7.) $8Z - 4Z = 34$

8.) The expression $7x$ represent the length of the shortest side of a triangle. The longest side is 2.9 times the length of the shortest side. What is the length of the longest side in terms of x ?

9.) Express the length of dimension A on this strap in terms of dimension T.

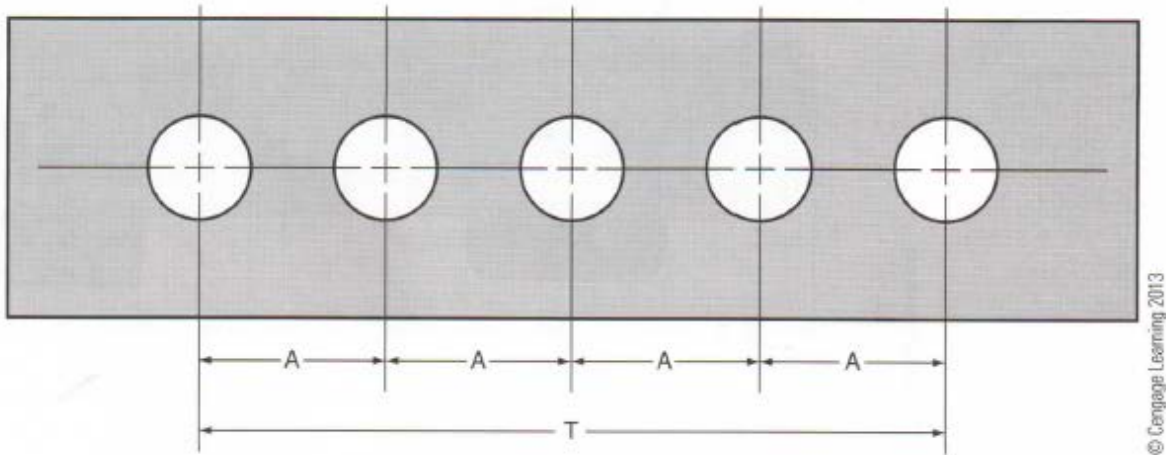

© Cengage Learning 2013

10.) Express the length of dimension L on this template in terms of dimension D.

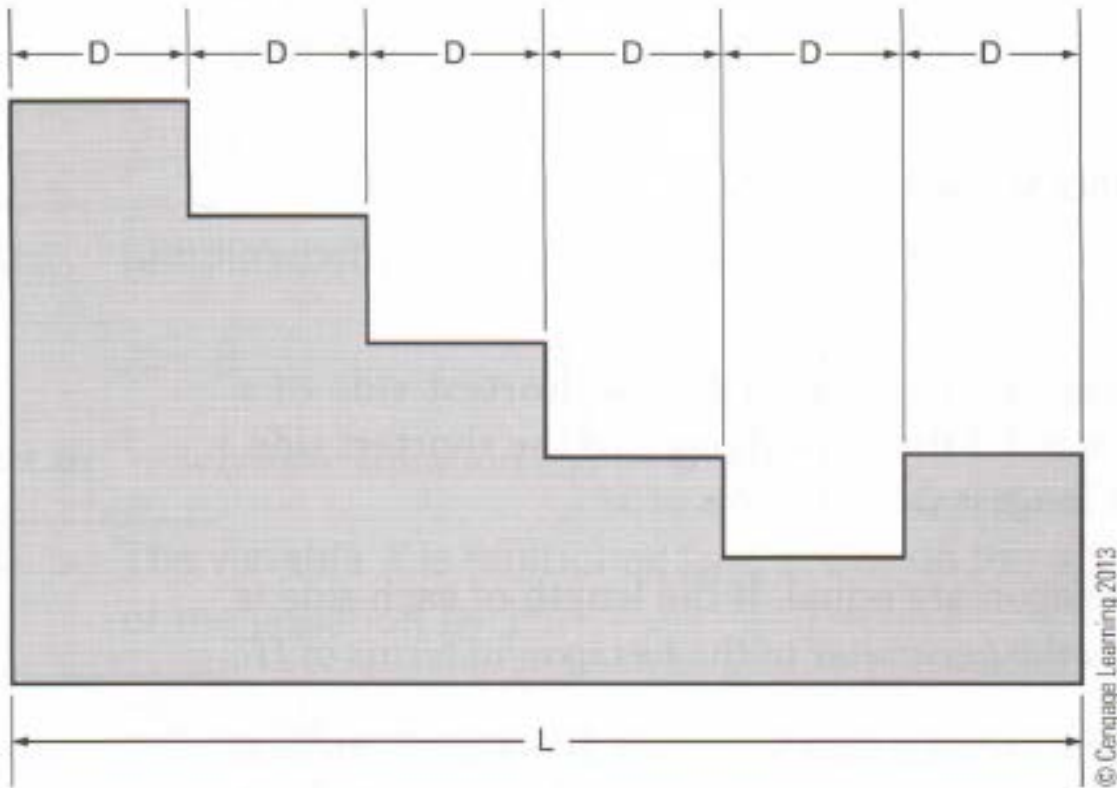

© Cengage Learning 2013

Name: _____
Mathematics Period 3

Date: 5/1/15
Ms. Wilson

**Expression and Equations
Homework – Due 5/4/15**

1.) The sides of a regular hexagon are equal. If the length of each side is express as $9.5H$, what is the perimeter of the hexagon in terms of H ?

2.) The circumference C of the circular base of a cylinder is 21.87 inches. What is D , the diameter of the base, to the nearest hundredth inch?

3.) The width of a rectangle is $24\frac{3}{8}$ inches. Its length is $17\frac{3}{16}$ inches longer than its width. What is L in inches?

4.) The dimensions on the CAD figure below are expressed in terms of the variable X . Express dimensions A , B , and C in terms of X .

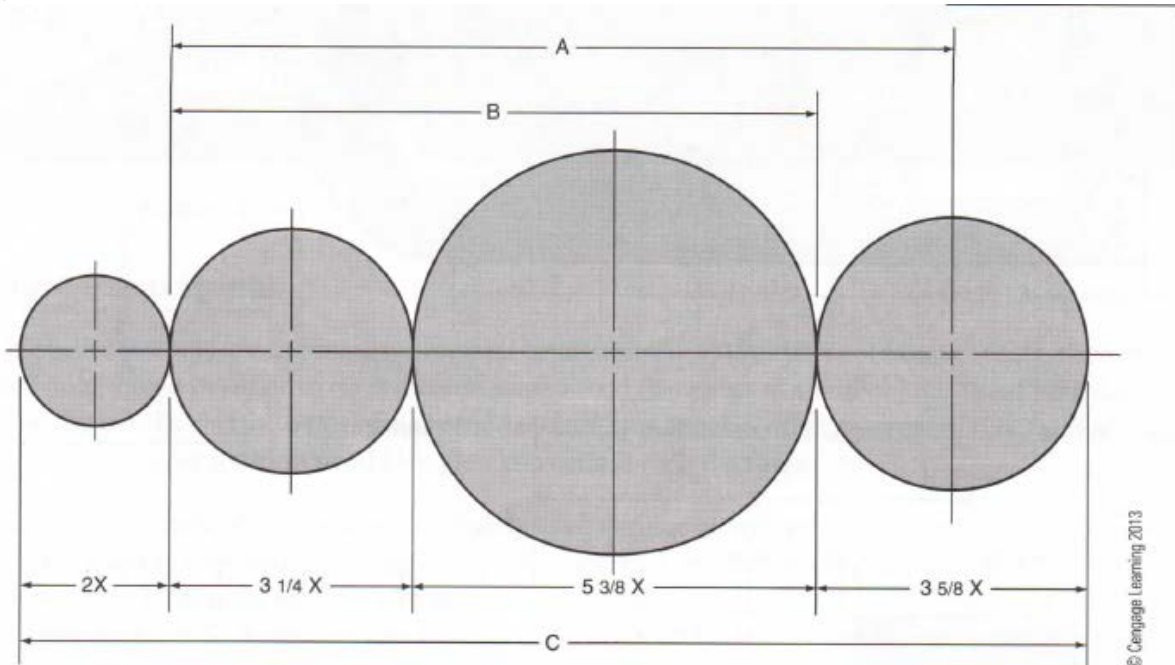

5.) Calculate the value of X in the CAD drawing of the bolt and nut below. Then use the value of X to calculate dimensions A, B, C, and D.

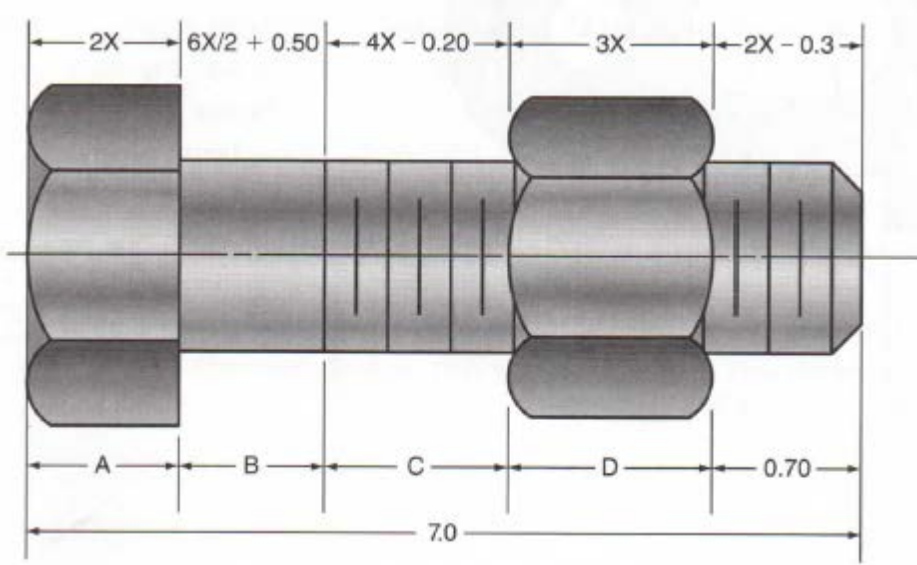

6.) In this CAD illustration, dimension B is 1.35. What is dimension Z?

